

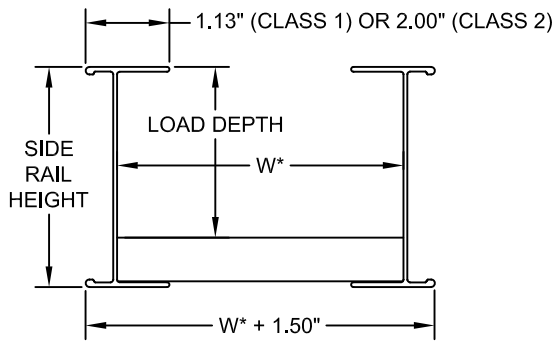

NO.	REVISION	BY	DATE	MATERIAL I.D.
0	APPROVED	TM	09-11-17	60H

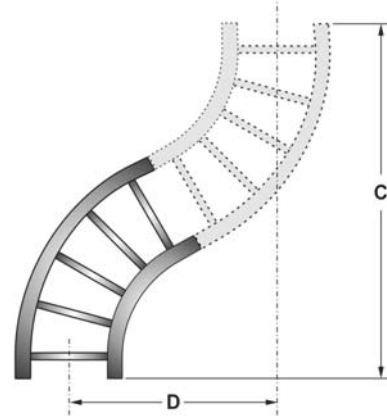
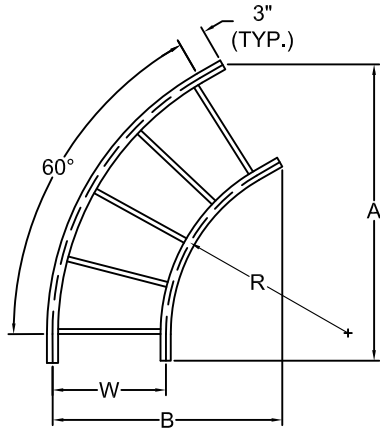

TRAY CROSS-SECTION

**CATALOG NUMBERS** ‡ MARK "✓" IN BOX TO INCLUDE IN SUBMITTAL

**MATERIAL**  
 ALUMINUM

EXAMPLE: **A62 - 09 - 60H24 - 12 - G**

SIDE RAIL HEIGHT	LOAD		FITTING CLASS	RUNG SPACING		FASTENER FINISH
	NOMINAL	ACTUAL		DEPTH	‡	
4	4.25"	3"	1 1.13" FLANGES	06	6"	G GEOMET PLATED STEEL
5	5.25"	4"		12	12"	
6	6.25"	5"	2 2.00" FLANGES	12	12"	S TYPE 316 STAINLESS STEEL
7	7.25"	6"		VT	5"	

INCLUDED ITEMS	CATALOG NO.*	QTY.
SPLICE PLATE, STANDARD 4 HOLES, 5-1/4"L SUPPLIED IN PAIRS	SPS-A(H*)-(G OR S)4	1 PR.
RIBBED-NECK SCREW PHILLIPS RECESS 3/8" DIA. x 3/4" LONG	F-RNS-38-34-(G OR S)	8 EA.
FLANGED HEX NUT 3/8" DIA., SERRATED FACE 9/16" SOCKET SIZE	F-FHN-38-(G OR S)	8 EA.

(H\*) = NOMINAL SIDE RAIL HEIGHT (4, 5, 6, OR 7)

**SPLICE PLATES:** NECESSARY SPLICE CONNECTORS AND FASTENERS ARE AUTOMATICALLY SUPPLIED WITH ALL TRAYS. SPLICE RESISTANCE IS LESS THAN 0.00033 OHMS. FASTENER FINISHES ARE GEOMET-PLATED STEEL (G) AND TYPE 316 STAINLESS STEEL (S).



CLASSIFIED BY UNDERWRITERS LABORATORIES AS TO ITS SUITABILITY AS AN EQUIPMENT GROUNDING CONDUCTOR ONLY PER NEC 392. METAL CABLE TRAY IN ACCORDANCE WITH THE STANDARD FOR CABLE TRAY SYSTEMS CAN/CSA-C22.2 NO. 126 (UL FILE NO. E341872)

**MATERIAL:** EXTRUDED ALUMINUM ALLOY 6063

**FINISH:** PLAIN

**TRAY TYPE:** LADDER, TWO RAILS

**BOTTOM:** 1.13" WIDE RUNGS (TUBULAR WITH OPEN SLOT)

**CONSTRUCTION:** ARC-WELDED ON BOTH SIDES OF RUNGS

**FITTING CLASS:** 1 (1.13" FLANGES) OR 2 (2.00" FLANGES)

**TANGENTS:** 3" (FLAT SIDE RAIL BEYOND CURVATURE)

THIS CABLE TRAY SYSTEM IS IN FULL COMPLIANCE WITH ALL ASPECTS OF THE LATEST REVISIONS OF NEMA STANDARD VE1, CSA C22.2 NO. 126 AND THE NATIONAL ELECTRIC CODE ARTICLE 392.

‡	ITEM CODE	RADIUS - WIDTH	FITTING DIMENSIONS (INCHES)				
			R	W	A	B	C
	60H12 - 06	12 6	20-1/8	14-5/8	35	20-1/4	
	60H12 - 09	12 9	22-5/8	17-5/8	37-5/8	21-3/4	
	60H12 - 12	12 12	25-1/4	20-5/8	40-1/8	23-1/4	
	60H12 - 18	12 18	30-1/2	26-5/8	45-3/8	26-1/4	
	60H12 - 24	12 24	35-5/8	32-5/8	50-5/8	29-1/4	
	60H12 - 30	12 30	40-7/8	38-5/8	55-3/4	32-1/4	
	60H12 - 36	12 36	46-1/8	44-5/8	61	35-1/4	
	60H24 - 06	24 6	30-1/2	20-5/8	55-3/4	32-1/4	
	60H24 - 09	24 9	33-1/8	23-5/8	58-3/8	33-3/4	
	60H24 - 12	24 12	35-5/8	26-5/8	61	35-1/4	
	60H24 - 18	24 18	40-7/8	32-5/8	66-1/8	38-1/4	
	60H24 - 24	24 24	46-1/8	38-5/8	71-3/8	41-1/4	
	60H24 - 30	24 30	51-1/4	44-5/8	76-1/2	44-1/4	
	60H24 - 36	24 36	56-1/2	50-5/8	81-3/4	47-1/4	
	60H36 - 06	36 6	40-7/8	26-5/8	76-1/2	44-1/4	
	60H36 - 09	36 9	43-1/2	29-5/8	79-1/8	45-3/4	
	60H36 - 12	36 12	46-1/8	32-5/8	81-3/4	47-1/4	
	60H36 - 18	36 18	51-1/4	38-5/8	87	50-1/4	
	60H36 - 24	36 24	56-1/2	44-5/8	92-1/8	53-1/4	
	60H36 - 30	36 30	61-5/8	50-5/8	97-3/8	56-1/4	
	60H36 - 36	36 36	66-7/8	56-5/8	102-1/2	59-1/4	

**ATKORE**

560 WHARTON CIRCLE, SUITE E PHONE: 404-696-8585  
 ATLANTA, GA 30336 USA FAX: 404-696-8599

SHEET NO.  
1 OF 1

DIMENSIONS  
INCHES

**DESCRIPTION**  
60° HORIZ. ELBOW, LADDER & VENT. TROUGH CABLE TRAY, CLASS 1 & 2

**DRAWING NUMBER**  
USP-60H-LA-1-2